

MINIMAX

ENG

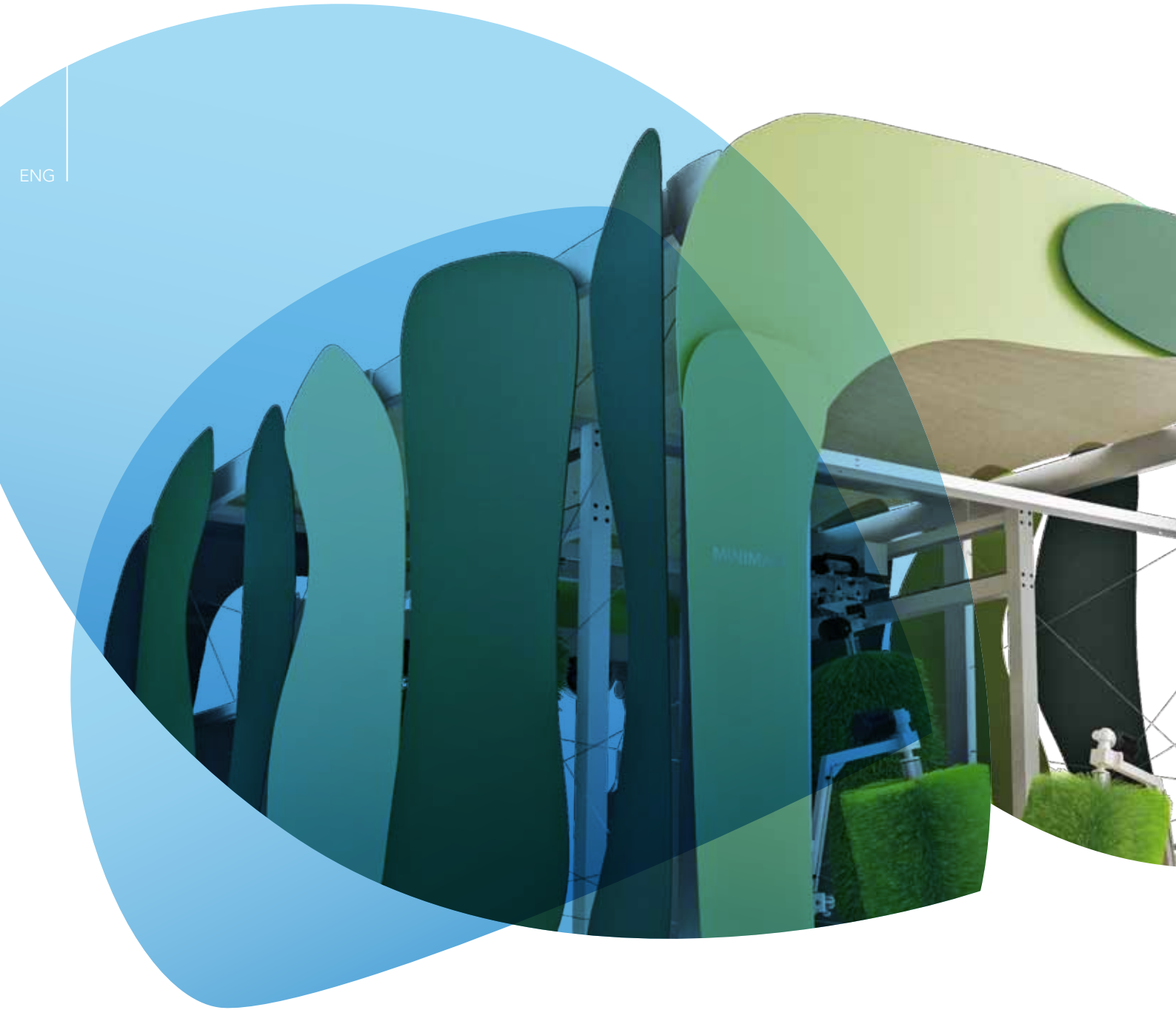

MINIMAX

GREAT PERFORMANCE IN SMALL SPACES

With MiniMax, Ceccato presents a system with extremely limited overall dimensions (just over 9 metres of structure in its smallest configuration) and excellent productivity. Complete, reliable, and innovative.



MINIMAX offers

a unique modern design to capture the attention of your clients;

versatility in installation and optimization in use, made possible by the self-supporting structure;

the safety and look guaranteed by the protective devices and side coverings, as well as the newly developed drive system;

total and precise washing and drying, with results that can easily be compared to those offered by high-end gantry but with almost double the productivity;

the choice of accessories and optional washing groups for even better results;

sophisticated software to control the brushes and patented drying system. Air Plus unites advanced technology with unsurpassed simplicity.

High-quality construction, balanced price-quality ratio, low operating costs, energy savings and low environmental impact: these are just some of the other strong points of a system that plays an important role in the Ceccato product range, guaranteeing quick return on your investment.

TECHNICAL FEATURES

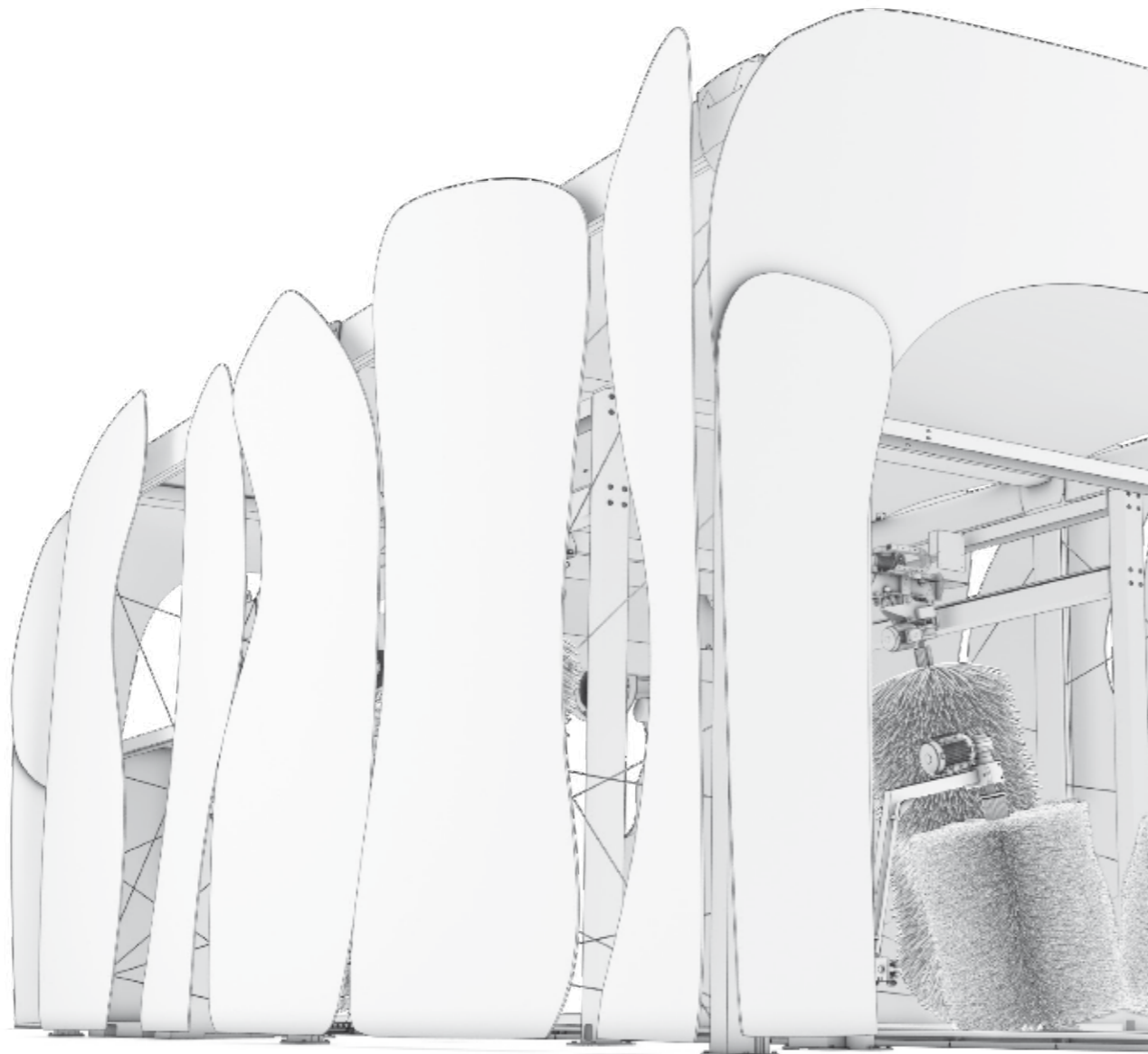

Description of the tunnel sections

ENTRY section

- .Vehicles towing system
 - .designed for best reliability, safety and speed
 - .contact of the vehicle rim wheels with the walls of the runway is avoided, thank to the special conformation of the conveyor frame
 - .thank to the open upper side of the towing chain guide, it is possible to wash with the utmost safety even low body sport cars
 - .the conveyor frame includes modules of different length: 3 meter, 1,5 meter, and 0,75 meter

PRE-TREATMENT (option)

Pre wash is carried out to prepare the vehicle for the following main wash, avoiding that mud and dirt particles attached to the body are removed directly by the brushes, damaging the painted surfaces.

- .Fixed pre wash cleaner arch
- .Fixed high pressure rinsing arch

OPTIONAL WASHING GROUPS

This section includes drying groups and products application systems, to complete and improve the washing process.

- .Wheel wash
- .Super wax application arch

5-BRUSHES WASHING GROUP*

The main cleaning phase in the washing process is carried out in this section. The top brush of the group is controlled by a vectorial system and works with outstanding accuracy; the results can be compared to the wash quality achieved by high level gantry type units.

The side wash groups include:

- .one pair of short side brushes completing the washing action of the vehicles lowers parts
- .one pair of translating brushes that follow the vehicle with a linear travel of up to 2,1 meter during the washing phase

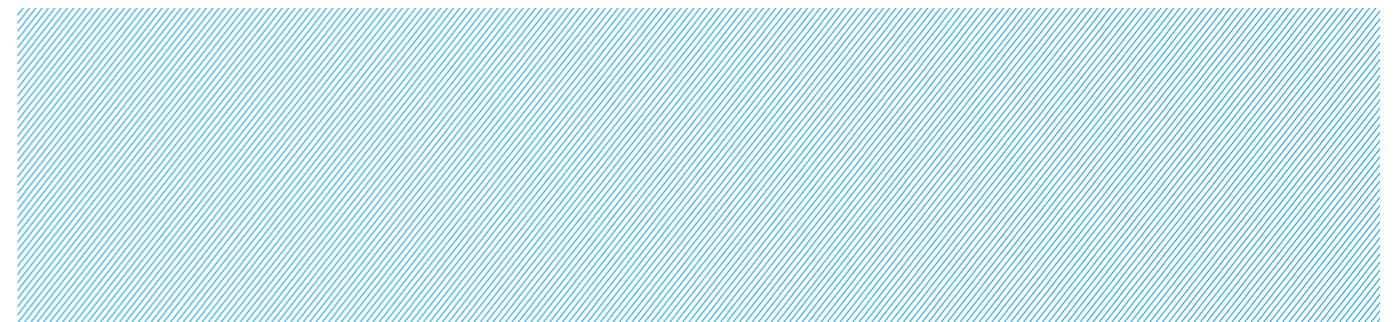

*3-brushes washing group



DRYING section

The problem of noise level was closely examined during the developing phase. Some effective technical solutions have been adopted in order to reduce sound emissions and, at the same time, to guarantee very good drying results. MINIMAX is equipped with the Air Plus drying system, a largely adopted solution in the latest Ceccato units, which outstanding feature is the displacement of large air volumes. This solution assures a very high drying capacity, very low sound levels, simple operation and easy maintenance of the system.

EXIT section

The vehicle is pulled by the conveyor chain out of the tunnel, passing through an exit arch which design is similar to the one of the entry arch. The green lamp of the traffic light system, positioned at some distance from the tunnel exit, switches on when the vehicle is released from the pulling chain and can be safely driven away.

Technical features

.Double hydraulic circuit for recycled water

Overall dimensions (mm)

Conveyor chain length	modules, upon request
Unit width	5900
Unit height	3660* / 4360**
Washing width	2200
Wheel runway width	350
Washing height	2300

* without roof and gutters

** with roof and gutters

Technical data

Power supply (V)	400 ± 10%
Installed power (kW)	variable, depending on machine configuration (power of basic configuration: 25***)
Frequency (Hz)	50 / 60
Conveyor speed	3 meters per minute

*** pumps not included

Proposed solutions

MINIMAX DYNAMIC

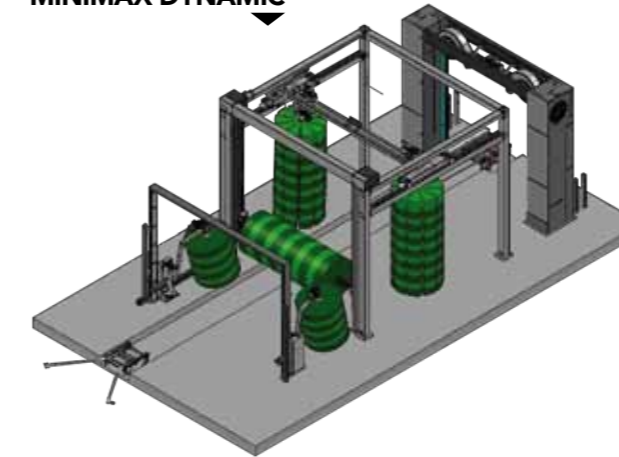

MINIMAX SMART

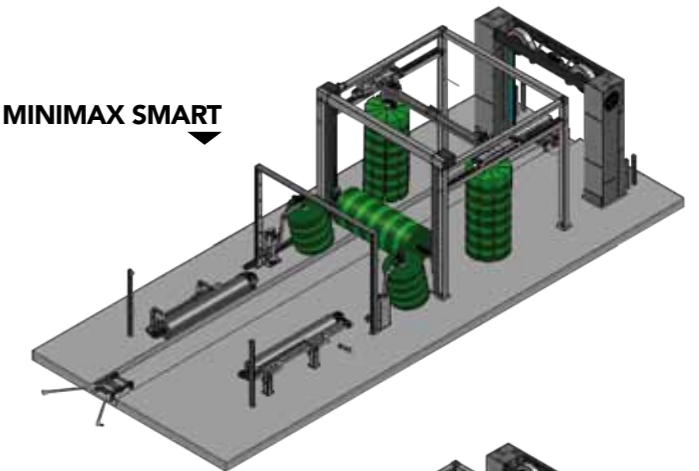

MINIMAX EDITION

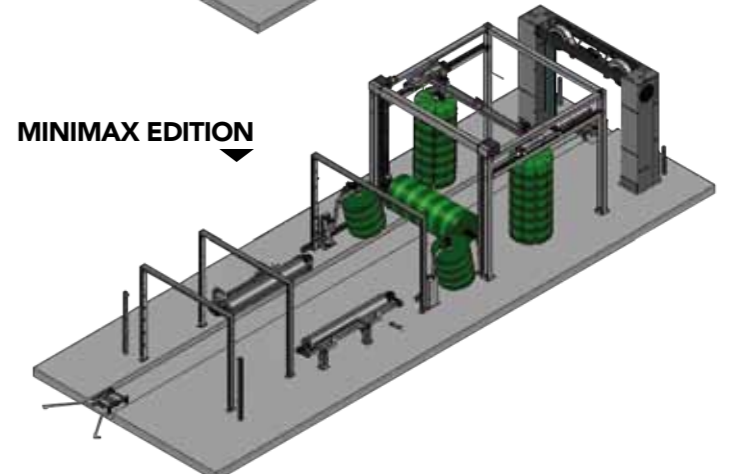

There's always another road to choose.

One which takes us beyond our limits and habits to let us try different routes and explore new horizons, with a dedication to results and a drive to innovate, aware of goals reached, and ready for new challenges.

In this world so mobile we're taking cleaning further, to where true hygiene, ecology and value become one, where a means of transport is truly about comfort, wellbeing and freedom; and where our ideas, research and technology are blending to build the future.

It will be an exciting journey: we'll take it together.

Ceccato s.p.a.

via selva maiolo 5/7
36075 Alte Ceccato
di Montecchio Maggiore
Vicenza - Italy

t +39 0444 708 411
f +39 0444 708 405
info@ceccato.it
www.ceccato.it

